

Date:		Class:		Center			
Track				Silicone Tubing Configuration:			
Track:				Silicone Tubing Lube:			
Surface:				Side Damper Tube Lube:			
		Left	Right	T-Plate:			
Front				Chassis			
Castor				Cross Weight		Right Side %	
Reactive Castor				Total Weight		Left Side %	
Camber				Chassis			
Spring				Front End			
Spring Brand				Traction Compound:			
Spring Retainer				Speed Control:			
King Pin Lube				Battery:			
Tire Compound				Body:			
Camber Cut				Motor			
Tire Diameter				Motor:			
Weight				Rotor:			
Dual Rate				Winds		Timing	
Toe				Pinion		Free Rev Amp	
Steering Block				Spur		Roll Out	
Servo				Results			
Rear				Heat 1:		Heat 2:	
Rear Steer				Heat 3:		Qualify Position:	
Tire Compound				Main:			
Tire Diameter				Notes:			
Weight							
Differential							
Pod Droop							

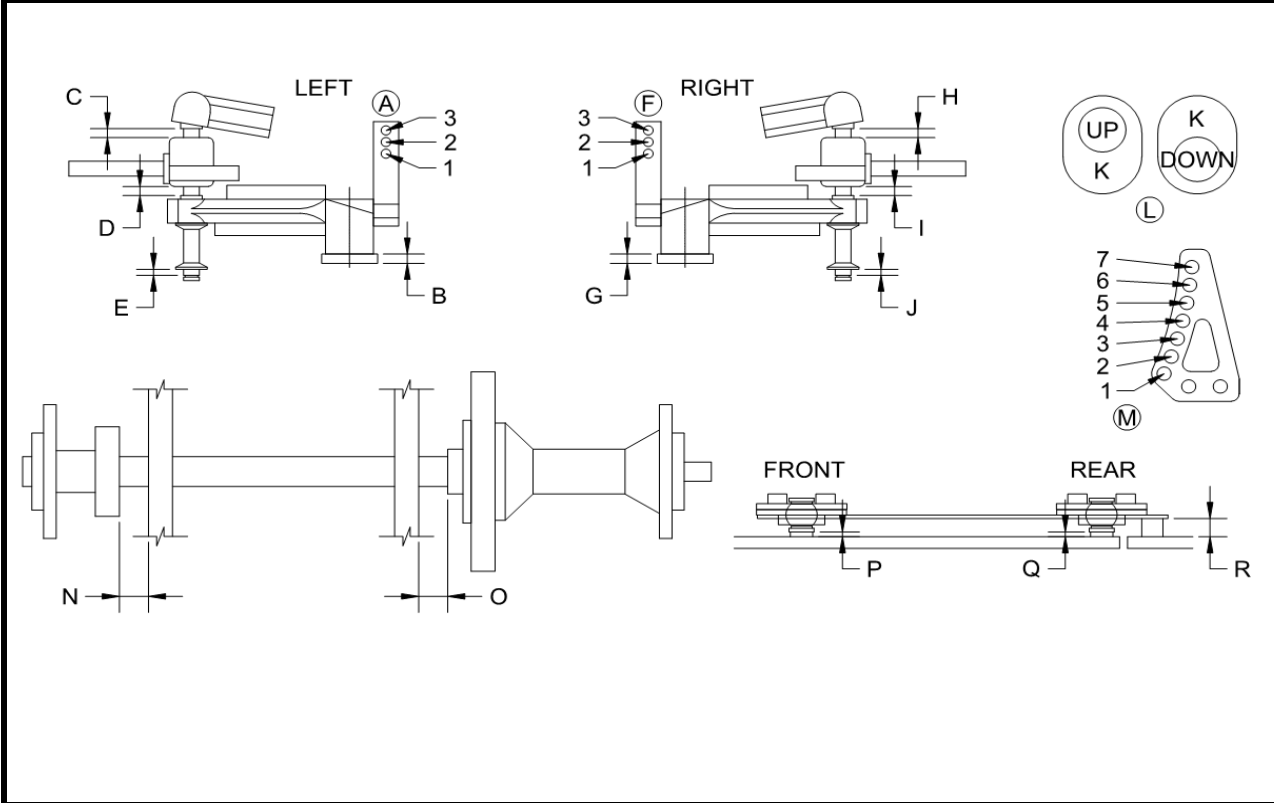

A	
B	
C	
D	
E	
F	
G	
H	
I	
J	
K	
L	
M	
N	
O	
P	
Q	
R	